

CO₂ INCUBATOR



Instruction Manual



Model : LCI - 200B

Please read this manual carefully before using the instrument

Labnics Equipment

COPYRIGHT

1. Without the written permission of our company, any content of the manual should by no means be duplicated or disclosed to any other individual or organization.
2. Individual or organization should in no way use the manual unless authorized by our company.
3. Our company has the sole right to change or modify this manual. Any other individual or organization thereby should in no case change or modify the manual.
4. Without our written permission, any organization or individual should not, by the name of sale or donation, provide public the manual or the duplication of the manual.
5. Anyone who violates our copyright must be pursued according to the copyright law.

LABNICS EQUIPMENT

- No part of this publication may be reproduced or transmitted in any form by any means, including photocopying and recording, without the written permission of **LABNICS EQUIPMENT**.
- Various sections of this operating manual may be copied only for in-house use by the equipment operator, e.g. to provide employees with instruction on accident prevention measures. These sections are clearly marked in the list of contents.
- **LABNICS EQUIPMENT** can accept no liability or responsibility for the marketability or the suitability of his operating manual for a certain purpose other than that specified under "**Areas of application of equipment**".
- **LABNICS EQUIPMENT** reserves the right to change the version of this operating manual at any time and without prior notice.

Environmental Conditions:-

- Indoor use.
- Altitude up to 2,000 m.
- The working temperature of the surrounding must be in 18°C--30°C when the unit works in 37°C.
- Maximum relative humidity is 80% for temperatures up to 30°C.
- **MAINS** supply voltage fluctuations up to ± 10 & of the nominal voltage.
- Transient over voltages typically present on the **MAINS** supply category II.
- Applicable RATED POLLUTION degree 2.
- The room must be equipped with adequate ventilation.
- The setup surface must be firm, level, and nonflammable.
- The unit must be set up where it will not be in direct sunlight.
- There is not any hot source nearby the unit.

Safety Information:

- It is important for you to read this Instruction Manual carefully before using the unit for the first time.
- The CO₂ Incubator may only be operated by trained, authorized personnel.
- Maintenance work on the unit may only be performed by the **LABNICS EQUIPMENT** or authorized agents.
- Tissue, materials, or liquids:
 - Which are highly flammable or potentially explosive.
 - Whose vapors form flammable or explosive mixtures with air.
 - Which release toxins; May not be used.
- The pressure of the CO₂ supply can be adjusted to a range of 0.8-1 bar, and cannot be altered.
- CO₂ is a kind of gas representing potential health hazard. The unit is to be repeated at suitable intervals.
- Only qualified personnel using suitable tools may work on supply lines and compressed gas container, bottles, or collective systems in which CO₂ is stored for use with the incubator.

WARNING



Warning: Important operating and maintenance instructions. Read the accompanying text carefully.



Caution, Hot surface



Warning: Carefully for the glass.

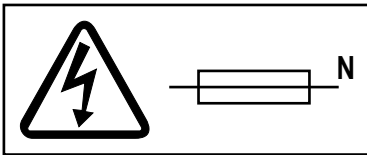

Caution: Double pole/ Neutral fusing.



Warning: Turn off the UV lamp before opening.



Protective conductor terminal



Caution, Risk of electric shock

Simple Operational Procedure of LCI-200B CO₂ Incubator

Default Set Temperature:-37°C, % CO₂-0 %.

Please perform 90 ° C moist heat disinfection before first using.

Then the following procedures should be strictly followed:-

1. Open the outer door and the glass door and put distilled water (3L) into the pool. Now close the doors after doing so.
2. Connect the unit to the source of CO₂.
3. Connect the power supply and switch on.
4. Self-checking will be done automatically. [%CO₂] and [°C] will display [888] and version number. The checking will be terminated after 40sec. [% CO₂] and [°C] display the setting data inside the unit.
5. Press the [auto-start] for about 10s, then the "**auto-start**" light will be lit.
6. Please open the glass door according to the hints of the [% CO₂] and [°C] display windows.
7. Close the glass door after 1 minute, and the unit will do **AUTO-START**.
8. Wait for 16 to 24 hours.
9. Adjust the exit pressure of CO₂ source to 1bar (0.1MPa).
10. Press [% CO₂] and [▲]/[▼] to input CO₂ setting value (eg.5.0%, 7.0% or 0%).
11. Unit will input the CO₂ gas until the setting value.
12. Now, the unit can be used in incubating work.
13. You must set the CO₂ value to [.0%] according to the "**Step 10**" after operating before switching off.
14. Open the glass window to spill out the gas, and dry the inner chamber.

Table of Content

S. No.	Contents	Pg. No.
1.	Control Panel	1
2.	Introduction	2
3.	Application	2
4.	Equipment Description	2
4.1	- Structure	2
4.2	- Inner Component	2
4.3	- Heating System	3
4.4	- Humidity	3
4.5	- Gas source	4
4.6	- Door Switch	4
4.7	- Press Compensation	4
5.	Micro Control System	4
5.1	Data Control	5
5.1.1	- Temperature	5
5.1.2	- CO ₂ Control	5
5.2	Self-adjustment of Measuring System	5
5.2.1	- Regular AUTO-START Function	5
5.3	Supervisor Function	5
5.3.1	- Door Control	5
5.3.2	- Malfunction Identification	5
5.3.3	- Error Range	6
5.3.4	- Wrong Message	6
5.3.5	- Code Table of Malfunction	6
5.4	Special Functions	6
5.4.1	- Buzzer on / off (function 1)	6
5.4.2	- Gas Supply on / off (function 2)	6
5.4.3	- CO ₂ zeroes (function 30)	6
5.4.4	- Lock the SET Point (function 4)	7
5.4.5	- Door Heating: On/Off (function 5)	7
5.4.6	Heating Way: Normally/Slowly (function 6)	7

S. No.	Contents	Pg. No.
5.4.7	- Monitoring the surrounding temperature (function 8)	7
6.	Overheat Protection	7
7.	Placing Position and Installation	7
7.1	- Positioning	7
7.2	- Space	8
7.3	- Stacking	8
7.4	- Installation and Connection of Gas Source	8
7.5	- CO ₂	8
7.6	- Attention	8
7.7	- Put through the Main Power	8
8.	Startup	9
8.1	- Adjust the SET Point	9
8.2	- Default Set	9
8.3	- AUTO-START	9
8.4	- Special Functions	10
8.5	- Attention	10
8.6	- [I] key	11
9.	Table of Malfunction Code	11
10.	Disinfection, Cleanness, and Examination	12
11.	90°C Moist heat disinfection	12
12.	Adjust the Data	14
12.1	Temperature Adjustment	14
12.2	%CO ₂ Adjustment	14
13	Technical Data	15
14.	Appendix	16
	Stacking of Incubators	16
	● Capacity of Gas	16
	● CO ₂ Inputting	17
	● PH value	17
15.	Service Report	18

CHAPTER 1. CONTROL PANEL:-

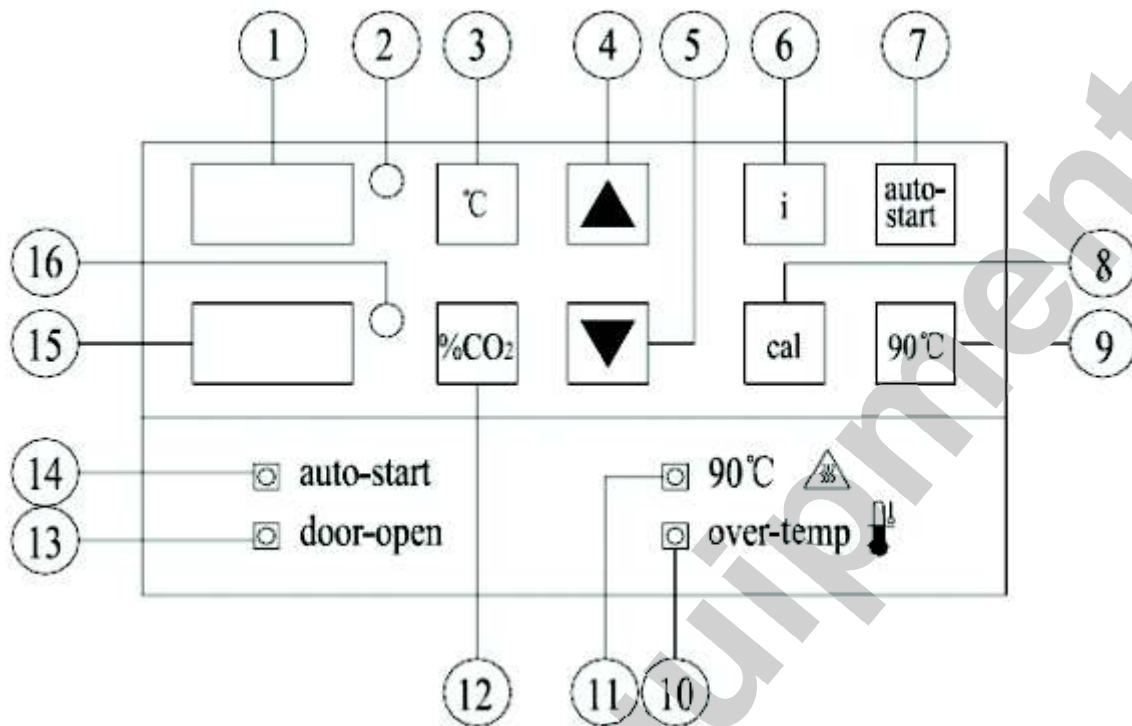

Simple Introduction of Display Panel:-

1. "°C" Display Window:
 - " Display the actual value at normal condition. The SET value can be displayed by pressing [°C] key.
 - " The code of temperature malfunction can be displayed by pressing [i] key and you can also switch to the special function mode by pressing [cal] key (See function).
2. Heating light will lighten as heating progress.
3. [°C] is used to set the temperature.
4. [▲] is used to increase the value.
5. [▼] is used to reduce the value.
6. Press [i] key will display the malfunction code.
7. Press [auto-start] key for 10sec to enter the Auto-start mode.

Control Panel:-

8. Press [cal] key for over 5 seconds to enter the adjusting mode. Select special functions together with [▼] and [▲] key.
9. Press [90°C] key for 10sec to enter the disinfection at 90°C.
10. "**Over-temp**" will lighten if the temperature is over the set value and the heating progress will be terminated.
11. "90°C" light will lighten when the equipment begins disinfection at 90°C.
12. [%CO₂] is used to set concentration of CO₂.
13. "**Door-open**" light will lighten when the glass door is opened.
14. "**Auto-start**" light will lighten when the equipment begins Auto-starting.
15. "%CO₂" display window displays the actual value of CO₂ concentration; the SET value can be seen by pressing [%CO₂] key. The code of CO₂ malfunction can be displayed by pressing [i] key; you can also switch to the special function mode by pressing [cal] key (See Function Select).
16. GAS light will lighten when the gas comes in.

CHAPTER 2. INTRODUCTION:-

- **LCI-200B** Incubator is delicate laboratory equipment mainly used in medical area & incubation of cells, tissues and bacilli. There are new functions like disinfection at 90°C, the control of CO₂ concentration, and the Micro Control System, which improves the incubation of cells, tissues and other materials. It is an important equipment of High Leveled biological and medical experiments.

Please carefully read this manual before using in order to prevent the inconvenience & the damage to the equipment.

- Only the personnel authorized by **LABNICS EQUIPMENT** can do the necessary test or maintenance work in order to keep the incubator work normally and accord with the corresponding safety standards.
- Please note the Serial No. while handling the malfunction report or speak for components.
- Only authorized or trained personnel can operate the equipment.
- Please keep the incubator in steady environment without acute change of temperature, which is helpful to the incubation.
- The equipment quotes the following standards:
 - Q/TEUC8-2002 (LCI-200B)
 - EN 61010-2-010
 - Common equipment of Class I.

The important part is labeled by



CHAPTER 3. APPLICATION:-

The incubator can simulate the natural data of cells and tissues. The equipment **CANNOT** be used to incubate flammable materials.

CHAPTER 4. EQUIPMENT DESCRIPTION:-

4.1 Structure:-

1. Fabric Shell

- Electrolyzed galvanization steel (RAL 9002).
- Control parts are made of plastic.
- Stainless steel is used in inner chamber.

4.2 Inner Components:-

The insert shelves are shake resisted, and can be adjusted at 50mm height. You can remove the shelves and support frame simultaneously without any additional tools.

2. Six small doors

There are six small doors located in front of the inner chamber. The unique design can reduce the gas and the temperature lost when the front door is opened. Way of teardown (Refer to **Figure 2-1**). Open the small glass door at 45°, and lift slowly until it is completely removed.

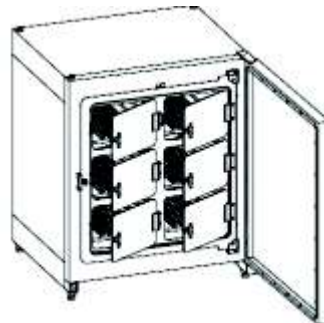
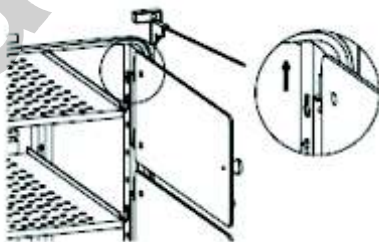

4.3 Heating System:-

The heating system is speeded on the surface of inner chamber to heat it. The heating system is normally placed at the top, back, front, left, right sides of the pool and the front of the outer door. The condensed water will not appear because the outer door is also heated so that it will keep clear. On the contrary, there will be condensed water on the outer door. The main heating system allows the equipment to run at the temperature 8°C above the Room temperature. If you want to operate at a lower temperature, you can switch off the door heating to make the equipment work at the temperature 5°C above the surrounding. There will be condensed water formed at the corner of the glass door. The door-heating switch is "ON" at normal condition (refer to function 5, P19), and the additional heating system is always on the new added slowly heating and normally heating mode could make the incubator work at the different temperature. Anyway, normal heating mode is suggested.

4.4 Humidity:-

The distilled water in the pool vaporizes and the air inside the chamber become humid, as the humidity at normal condition is =95%. The condensed water will not appear at the top of the chamber and on the door because a particular type of heating system is used. Instead, it will gather at the other sides of the inner chamber.

The container of the pool: 3L distilled water.

Please ensure that there is no chemical material in the water or it will canker the pool.

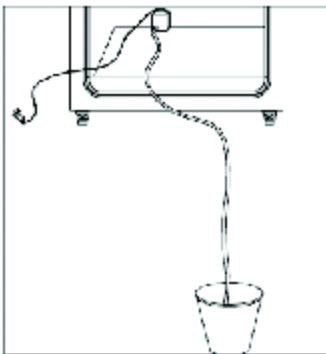

Fig.3: Draining
Each incubator is equipped with an electric suction pump.

Steps of Using:-

- Take out the draining pipe in the bag.
- Remove the lower shelf inside the chamber.
- Connect one point of the pipe to the discharge port of the electric suction pump.
- Put the other point into the bucket.
- Install the four osculums onto the back of chamber (below the wind channel) and put the bottom into the water.
- Educe the plug and put it into the 220V power jacket.
- The pump begins to work until the chamber is dried.
- Take off the plug and remove the pump from the chamber.
- Unplug the drainpipe and dry the pump.
- Dry the pool.

Attention of using the pump:

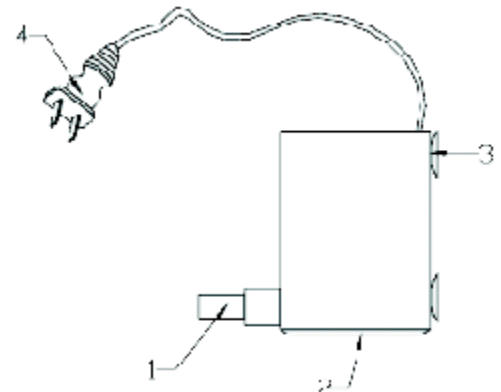

Fig. 4: Electric Suction Pump

1. Drainpipe
2. Bottom of Pump
3. Osculum
4. Plug

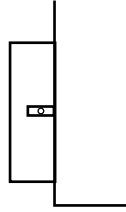

Fig. 5: CO2 Entrance

- The pump cannot run without sopping up.
- Do not make the pump run for more than 10 minutes.
- Drainpipe must be connected when draining.
- Dry the pump after draining.
- **Don't take water to the plug of pump because of the AC 220V working voltage.**

4.5 Gas Source:-

- The joint of the gas entrance is at the back panel of the equipment (refer to Fig 5).
- The maximum input pressure is **1 bar**.
- **Please carefully check the joint of gas entrance.**
- The gas will pass through a filter and enter the chamber after the grain larger than $0.3\mu\text{m}$ being sieved. The sieving ratio is 99.998%, and the blower mixes the inputting gas and the air present inside.
- **CO₂ gas should be high pure food-class gas.**

4.6 Door Switch:-

There is a switch at the back of the glass door. This switch will cut off the gas supply and prevent the overheating and gas entering into the heating system. All the display will glitter until the door is closed. If the door remains open for 5 minutes, the equipment will buzzer out an alarm. The outer door can only be closed when the glass door is closed and gastight.

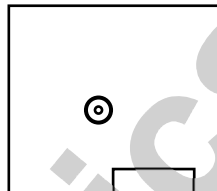

Fig 6: Pressure Compensation Hole

4.7 Pressure Compensation:-

The pressure compensation hole prevents the abnormal pressure at the time of entering of gas & assimilation of air when glass door is open (See Fig 6).

The equipment should be placed with good compensation to ensure the gas letting by valve can be cleaned in time.

CHAPTER 5. MICRO CONTROL SYSTEM:-

The System includes the following separated control function:

1 Data Control:-

Set Range:

- Temperature: 5.0°C - 50.0°C
- CO₂: 0.0% - 20.0%

2 CO₂ Zeroing:-

Adjust the CO₂ testing system

3 Supervisor:

- Door Control
- Wrong Message
- Malfunctions Restoration
- Codes of Malfunction

4 Special Function

- Buzzer: On/Off
- Gas Supply: On/Off
- CO₂ Adjusting
- Set Point: Lock
- Heating Mode: Slowly/Normally
- Door Heating: On/Off

5.1 Data Control:-

5.1.1 Temperature:-

A Pt 1000 resistance of Micro Control system controls the chamber temperature.

5.1.2 CO₂ Control:

In order to keep the stabilization of pH value of the samples, the concentration of CO₂ in the chamber should be controlled. The concentration of CO₂ depends on the expected pH value and the content of the buffer solution of NaHCO₃ in the incubation medium. The measure of CO₂ is a continuous process based on the thermal conductivity of the inner chamber. Thus, the input of CO₂ will cause the change of thermal conductivity inside the chamber and form a signal that indicates that there is a direct ratio between thermal conductivity and concentration.

5.2 Self-adjustment of Measuring System:-

5.2.1 Regular AUTO-START function:-

- The Measuring System needs adjustment before operating or modifying the SET temperature. It will be preceded when **AUTO-STARTING**.
- The equipment will do self-adjustment to the measuring system when the temperature and humidity both reaches the steady state. The process takes 15 hours, if it is started at the room temperature.
- Please ensure that the chamber is only filled with air.
- **Suggestions:** Do **AUTO-START** every six weeks or whenever temperature is changed!

5.3 Supervisor Function:-

5.3.1 Door Control:-

All the displayed actual values will glitter until the glass door is closed. The 5 minutes lasting of door opening will be considered as malfunction and a malfunction code will be given out.

5.3.2 Malfunction Identification:-

Micro control system supervises all the data and possible malfunctions. All the SET value has a range, and the equipment will give an alarm together with the wrong message if the actual value is out of the range.

5.3.3 Error Range:-

- **Temperature:** $\pm 0.5^{\circ}\text{C}$
- **CO₂:** $\pm 1.0\% \text{CO}_2$

5.3.4 Wrong Message:-

Each malfunction identified by **Micro Control System** has a special code that will help you recognize the reason of malfunction. The radiation digital tube will glitter when malfunction occurs to inform you the situation, and if the buzzer is connected, you will also hear the sound signal. If you keep pressing [i] key, you will get the code of malfunction on the display, and if there is no faults, it will display [---].

Attention:

Please press [i] key to get code at the first time when malfunction occurs.

Following actions may interrupt wrong Message:

- * Change the SET value
- * Switch on/off the equipment

5.3.5 Code Table of Malfunction:-

Code of Malfunction	Possible Reason	Solutions
99 Glass door is open	Glass door is not closed	Close the door
100 Temperature too low (Set points)	Door heating is switched off	Switch on the door heating (Function 5)
101 Temperature too high (Set points)	Surroundings temperature too high	Switch off the door heating (Function 5)
200 CO ₂ too low (Set points)	CO ₂ not connected CO ₂ is used up	Connect the gas Replace the CO ₂ bottle
201 CO ₂ too high (Set points)	Low pressure of CO ₂ entrance High pressure of CO ₂ entrance	Adjust the pressure to 1 Bar Adjust the pressure to 1 bar

5.4 Special Functions:-

Choose the following functions by [Ca] + [▼] or [▲]

5.4.1 Buzzer: On/Off:-

- **Function 1:**

You will hear a sound signal when malfunction occurs if the buzzer is on.

Switch off the buzzer: "**Silent**".

Default set: Buzzer is on.

5.4.2 Gas supply On/Off:-

- **Function 2:**

The gas source will be cut off if you choose "**Gas OFF**", and the green diode "**Gas**" will crush out.

Default set: Gas On; the green diode "**Gas**" lights when the gas enters.

5.4.3 Co₂ zeroes:-

- **Function 3**

If the warp of CO₂ display is too large, the function allows the manual zeroing of CO₂.

5.4.4 Lock the SET point:-

- **Function 4:**

This function allows you to lock the SET point of temperature and CO₂ SET value and these points will not change when the equipment is wrongly operated.

Default set: Unlocked

5.4.5 Door Heating: On/Off:-

- **Function 5:**

The main heating system allows the equipment to work at the temperature 8°C higher than the surrounding. If you want to operate at the temperature 5°C higher than the surrounding, you can simply switch off the door heating system. But condensed water will form on the glass door.

Default set: Door heating system on.

5.4.6 Heating Way: Normally/Slowly

- **Function 6:**

The two different heating ways ensure the working of equipment normally at different temperature. The "**Slowly Heating Way**" is suitable for high-temperature situation. Normally Heating Way is suggested.

Default Set: Slowly Heating

- **Operational Way: Default Set**

- **Function 7:**

This Set id to test the function of the incubator please set to 1.

Default Set: 1

5.4.7 Operational Way: Monitoring the surrounding temperature:-

- **Function 8:**

Monitor the surrounding temperature to make the temperature steady inside the chamber.

Default Set: Monitoring the surrounding temperature.

CHAPTER 6. OVER HEAT PROTECTION:-

Temperature Limit Controller (TLC):-

- There is a separated TLC to protect the incubator.
- When the temperature control circuit is out of control, the TLC will control the power in case it is 1.5°C higher than the set value. The red light (over-temp) will lit when TLC responds.
- If the TLC is charged with the controlling, please refer to the code table of malfunction to find out the reason.

CHAPTER 7. PLACING POSITION AND INSTALLATION:-

Open the box and take out the components.

7.1 Positioning:-

- The incubator should be placed at the irremovable place.
- Avoid direct irradiation from the sun.
- The place where incubator is placed should be dry and the surrounding temperature of the place should not be higher than 30°C (18°C -30°C is the most suitable).

- Keep the equipment at a leveled place and the bracket should be shake resistant and apyrous.
- CO₂ is required when the incubator is working, but also CO₂ is harmful to health, so the place where it is placed must be well ventilated. The gas discharged from the back panel must be immediately carried off. The equipment cannot work without ventilation device, thus, if several equipments are in the same room or the equipment is placed at the bottom of the lab, additional ventilation device is needed.

For the detail of gas releasing, please refer to the appendix.

7.2 Space:-

There should be some space left between the equipment and the wall or other instruments.

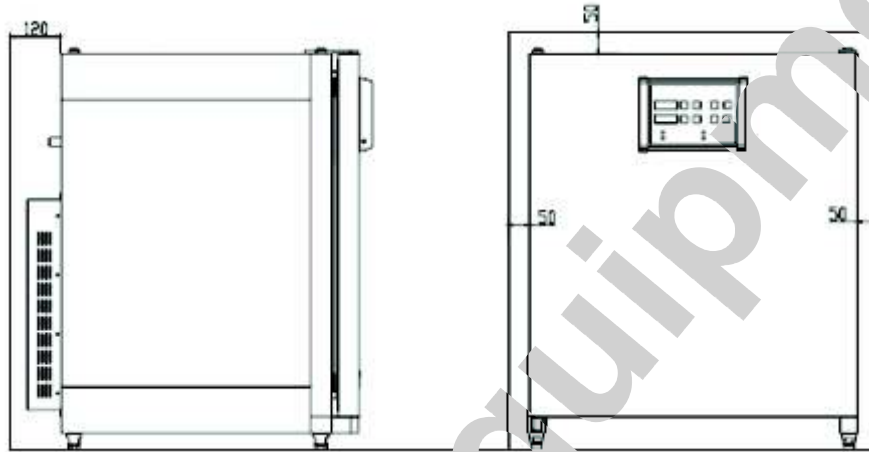

Fig. 7: Space between the LCI-200B incubator and the wall (mm)

7.3 Stacking: (See Fig. 9)

7.4 Installation and Connection of Gas Source:-

- The correspondent-connecting interface is at the back of equipment (See Fig. 5).
- The connecting pipe is included with the unit.
- The gas entering the equipment should first pass a reduction valve to reduce the pressure upto 1 bar.
- The pressure of 1 bar cannot be changed for safety reason.

7.5 CO₂:-

Connect the reduction valve to the equipment again.

7.6 Attention:- CO₂ gas should be non- toxic and its purity should be at least 99.5%. CO₂ Cylinder without seal should not be used.

The sensor with high sensitivity is used in this incubator, and it cannot be used under electromagnetic interference (e.g. mobile phone).

7.7 Put through the Main Power:-

Please ensure that the power supply matches the power written on the nameplate before putting through the power. There is a grounded power cable together with the incubator. The main power needs 24A fuses.

CHAPTER 8. STARTUP:-

1. The surrounding temperature should be least 8°C lower than the **SET** value.
2. Keep the outer door and glass door open.
3. Use Distilled water.
 - Pour the distilled water into the pool (approach the room temperature).
 - Input Quantity: 3L
 - Avoid overflow during the inputting.
 - Ensure the humidity inside the chamber will not change.
4. Open the cutoff valve of the bottle.
5. Switch on the main power.
 - The green light is on
 - [888] will be displayed for about 40S.
 - Regular Self-checking.
 - Actual value will be displayed after Self-checking.

8.1 Adjust the SET Point:-

Keys used: [°C], [▼]/[▲]

- Keep pressing [°C] key to adjust the [°C] value.
- Keep pressing [% CO₂] key to adjust the [% CO₂] value.
 - Display the value being set last time.
 - The last number of the display glitters.
 - Set the expected value by [▼] or [▲] key, and the value will be stored after loosening the SET keys and the actual value will be again displayed.

8.2 Default Set:-

- Temperature: 37.0°C
- CO₂ : 0.0%

Attention!

Only air gas can be in the chamber.

8.3 AUTO-START-

Keep pressing the [auto-start] on the control panel for 10S.

- **"OPEN DOOR"**: The temperature display panel will show [opE], "% CO₂" display panel will show [dor], and open the outer door and glass door for about 60S.
- The Auto-start mode is activated and the **"% CO₂"** display panel will show [0.0] & the "°C" display panel will show the actual value after closing the doors.
- **"GAS"** light is off and **"AUTO-START"** light will be on.

Close the doors

Attention:-

- Heat the equipment to the SET value and establish the relative humidity.
- After regular AUTO-START:
 - "Auto-start" light will be off
 - Actual value displayed
- The equipment will continuously input the gas until it reaches the SET value that has been set.
- The equipment can now be used in incubating work.

8.4 Special Functions:-

[cal] and [▼] or [▲] keys

- You can choose and set the special function by [▼] and [▲] key while keep pressing the [cal] key.
- "°C" will display the function code [1], and press [cal] again after loosen it, "% CO₂" display window will show the actual mode. The mode can be changed by pressing [cal]+[▼]/[▲].

Function Name	"C" Display Window	"%CO ₂ " Display Window	Function	Default Set
1 Buzzer	[1]	[A 1] [A 0]	On Off	On
2 Ventilation	[2]	[G 1] [G 0]	On Off	On
3 CO ₂ Zeroing	[3]	[.0]	CO ₂ Zeroing	
4 Opening Set	[4]	[S 0] [S 1]	Not opened Opened	Opened
5 Door Heating Switch	[5]	[d 1] [d 0]	On Off	On
6 Heating Way	[6]	[h 0] [h 1]	Slowly Normally	Slowly
8 Monitor the Surrounding Tempe.	[8]	[P 0] [P 1]	Not monitoring monitoring	Monitoring

8.5 Attention:-

1. Temperature:

- Please restart AUTO-START for calibration, when set temperature is over 1°C, which make the unit works precisely.

2. CO₂ Comparison:

- If the value of Co₂ concentration measured is different from the value showed on the [%CO₂], you can adjust Co₂ zeroing by manual. Unit will recover to the original CO₂ zeroing after next AUTO-START operation.

3. Example for Reference:

CO₂ display value: 7.0% CO₂

CO₂ actual value: 6.2% CO₂

- Choose function No. 3 by [cal] key and [▲] key.
- Loosen the [cal] key.
- Press the [cal] key again.
 - The [°C] displays [3] and glitters.
 - "%CO₂" display window shows [.0]
- Input the actual Co₂ concentration value into the temperature display window by [cal]+[▼]/[▲].
- Loosen the [cal] key.
- Press [] to confirm.

CO₂ will display the modified concentration. If the actual value is higher than the SET one, please keep the door open for one minute to let the extra gas out.

4. Important:

- Please pour out the water in the pool and dry the chamber if the equipment will not to be used for a period of time.
- Do not switch on/off the equipment continuously.
- Please keep the door closed and try to shorten the opening time when necessary to ensure the best situation of the chamber.

8.6 [i] key:-

If any malfunction occurs during work time, the corresponding display will glitter, and if the buzzer is connected, you will hear a sound alarm at the same time. You can know the reason of malfunction by pressing ?i? key, and the display window will show the code of malfunction.

(Refer to the table of malfunction code)

CHAPTER 9. TABLE OF MALFUNCTION CODE:-

Please check the following to solve the problem more quickly.

Code Of Malfunction	Reason Of Malfunction	Solutions
99 Glass door is open	Glass door is not closed	Close the door
100 Temperature too low (Set Points)	Door heating is switched off	Switch on the door heating (Function 5)
101 Temperature too high (Set Points)	Surrounding temperature too high	Switch off the door heating (Function 5)
200 CO ₂ too low (Set Points)	CO ₂ gas not connected CO ₂ bottle is used off CO ₂ entrance pressure is too low	Connect the gas input Replace the CO ₂ bottle Adjust the entrance press to 1 bar
201 CO ₂ too high (SET Points)	CO ₂ entrance pressure is too high	Adjust the entrance press to 1 bar

Please contact the maintaining engineer if the table above cannot solve the problem

• Malfunction that cannot be shown by the equipment

Malfunction	Way of Checking
- Equipment does not heat	- Check the SET value
- No gas entrance	- Check the diode GAS.
	- Check if the input is switched off. - Check the SET value
-Buzzer does not give out alarm when malfunction occurs.	- Check if the buzzer is switched on. Please check the special function.
- SET value cannot be changed	- SET point is locked. Please check the special function.
- There is much water on the glass door.	Check if the door heating is switched on.

Switch OFF:

- Switch off the main power
- Switch the gas reduction valve

CHAPTER 10. DISINFECTION, CLEANNESS, AND EXAMINATION:-

1 Need to Do Once a Week.

- Check the water level of the pool.
- Check if the entrance pressure is 1bar.

2 Clean the Chamber with 90°C moist heat disinfection (suggestion: once per 2 months)

- Switch off
- Open the glass door
- Dry the chamber

CHAPTER 11. 90°C MOIST HEAT DISINFECTION :-



Warning: Hot surface in Disinfection mode, don't touch and open the door.

- The whole procedure of 90 °C moist heat disinfection.

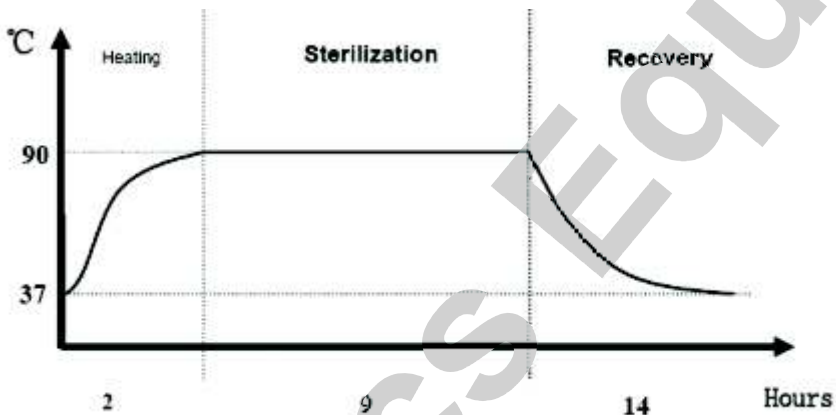

Fig: 8. The procedure of the 90°C moist heat disinfection

Way of 90°C moist heat disinfection:

- Open the outer and glass door, and take out all the materials inside the incubator.
- Dry and clean the incubator, and input 300ml distilled water.
- Close the glass and outer door. Turn on the power supply.
- Keep pressing the [90°C] button on the display panel until the green light "90°C" on the display panel lightens.
- Wait for about 10S, the "°C" display window will show [OPE] and "%CO₂" display window will show [dor]. **Please check if there is anything left inside the incubator!** Please do this after opening the outer door and the glass door.
- After keeping open for one minute, the "%CO₂" window will show [-25] and "°C" window will show the actual value of temperature and glitter, which indicates the disinfection procedure will last for 25 hours. Please close the doors!
- The equipment now begins the disinfection.

2. Explanation of 90°C moist heat disinfection.

The whole procedure is divided into three phases:

- **Heating** ---The heating procedure will increase the temperature to 90°C , and the procedure will last for 2 hours (based on surrounding temperature).
- **Sterilization**---The temperature has arrived 90°C , and the sterilization will last for 9 hours.
- **Recovery**---The equipment will return to the incubation mode (decrease the temperature), and the procedure will last for 14 hours.

Note: The procedure of disinfection may last for longer time in the condition where the heat is difficult to emit. If the procedure takes over 25 hours while the temperature has not recovered to 37°C, then "% CO₂" will always display [-4] (4 hours remains). At that time, operator can terminate the disinfection manually by pressing [90°C] key until the light goes out, which will not affect the disinfection.

3. Input 3L distilled water and do "**AUTO-START**" after disinfection. Incubation starts only after "**AUTO-START**". The "°C" window displays the actual value of temperature while the "%CO₂" window has three displays show the remaining time and remind you the current phase.

- **Phase 1**, the cursor of the "% CO₂" window is climbing in 1.
E.g. [-25] → [-25] → [-25]
- **Phase 2**, the cursor of the "% CO₂" window is at the middle and glittering in 2.
E.g. [-23] → [-23]
- **Phase 3**, the cursor of the "% CO₂" window is descending in 3.
E.g.: [-14] → [-14] → [-14]

4. Warning:

Please do the cleaning and disinfection process before informing the maintenance engineer.

5. Maintenance:

We can assure the normal condition of the equipment only when it is maintained or improved by the authorized engineers from **LABNICS EQUIPMENT**. The equipment should be overhauled every certain time to ensure the normal condition.

6. Suggestion: The equipment needs an annual check for the proper functioning of instrument. Each Incubator is checked properly before being used and also assures that it can suit your daily needs. Please contact the engineer of **LABNICS** if you want to keep it at top precision.

7. Condition for Normal Use:

- A Ambient temperature: 18°C -30°C
- B Relative humidity: <80%
- C There is no violent shake or corrosive gas near the equipment.
- D No effects from sun shine or other heat or cooling source.

8. LABNICS EQUIPMENT reserves all the rights of updating and improving of the product.

9 Warranty:-

- The warranty period is one year after purchasing.
- Our company will not take any responsibility, if the malfunction has been caused by improper handling and use of equipment even it is within the warranty period.
- Our company will responsible for the maintenance after the warranty period, but a certain amount of cost will be provided.
- Please show the related materials to the authorized personnel.

10. Protection Signals:-

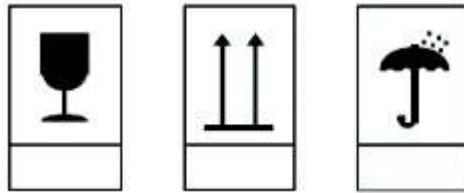

Avoid shaking, knocking and water during the transportation. Condition of transportation and restoration should be: **Temperature:** -40°C~+55°C, **humidity:** =95%.

CHAPTER 12. ADJUST THE DATA:-

The equipment should be adjusted regularly to ensure the best working condition. The user could adjust the equipment under the guidance of professional personnel at least once a year.

12.1. Temperature Adjustment:-

Put a thermometer with the minimum scale as 0.1°C into the center of the incubator. Wait for another 2 hours after the temperature value is steady, and note the actual value.

Way of Temperature Adjusting:-

- Open the outer door, observe the temperature inside the chamber and note it down.
- Close the outer door and keep pressing the [cal] key for more than 5S.
- Loosen the [CAL] key when the glittering "cal" appears on the display window.
- The "%CO₂" window will display the temperature value if you press the [°C] key.
- Adjust the temperature according to the noted actual value by pressing [▼] or [▲] key.
- Confirm by pressing [i] key.
- Repeat the above steps until the precise temperature.

12.2. % CO₂ Adjustment:-

The temperature and humidity of incubator is steady and keep the situation for more than 2 hours. The concentration of Co₂ should be 0%.

%CO₂ zero Adjustment:-

- Press [%Co₂]+[▼] to set "%CO₂" to ".0"
- Press [cal] key for more than 5sec.
- Loose the [cal] key when "CAL" is glittering in the temperature display window.
- Press [AUTO-START] once to make "0.0" appeared on the window.
- Loose [AUTO-START] and press [i] until the "0.0" is glittering on the window.
- The procedure will be completed after two or three minutes.

Adjust the Concentration of % CO₂:-

(The concentration should be higher than 2%, usually is 5%-7%)

- To set the concentration of CO₂ - 5.0%. Wait for more than 0.5 hour for stabilization, and then measure the real concentration.
- Press [cal] for more than 5 sec.
- Loose the [cal] key when "CAL" is glittering on the temperature display window.
- Press [% CO₂] once and the concentration will be displayed on "% CO₂" window.
- Adjust the concentration by pressing [▼] or [▲] according to the actual value.
- Confirm by pressing [i] key.
- Repeat the steps above until the value will become in accordance with the precision.

CHAPTER 13. TECHNICAL DATA :-

		DATA	UNIT
Size			mm
Shell	Width	780	mm
	Height	944	mm
	Depth	820	mm
Chamber	Width	607	mm
	Height	670	mm
	Depth	583	mm
Cubage		240	L
Shelf			
Number of shelves	Standard	3	Floor
	At most	12	Floor
Size	Width	554	mm
	Depth	503	mm
Net Weight		98	Kg
Electric data			
Rated Input Voltage		110	V~
Rated Power		0.735	kW
Rated Power Frequency		60	Hz
FUZE		AC130V F6.3A	
Digital Temperature Control			
Range		+5 - 50	°C
Power Cost at 50°C		± 0.1	kW
Chamber Deviation (DIN 12880)		0.4	°C
Transient Deviation (DIN 12880)		± 0.1	°C
Digital CO ₂ Control			
Set Range		0-20	% CO ₂
Set Precision		± 0.1	% CO ₂
Recovery Time		About 1	% CO ₂ /min
Gas Source		About 3.7	L/min
Humidity			
Relative Humidity Coat		>95	%
Texture Paint		9002	RAL
Data of gas source			
Filter	Ratio	99.998	%
	Grain	>0.3	µm
Strained Purity Ratio		99.5	%
At Least Entrance Press		1	bar
Yawp		<60	dB(A)
Capacity of Distilled Water		3	L

CHAPTER 14. APPENDIX:-

- The stacking of incubators (refer to Fig. 9).
- Capacity of gas under normal and abnormal condition.
- Appendix of CO₂ aeration (refer to Fig. 10).
- pH value based on the concentration of CO₂ (refer to Fig. 11).

Stacking Figure of LCI 200B

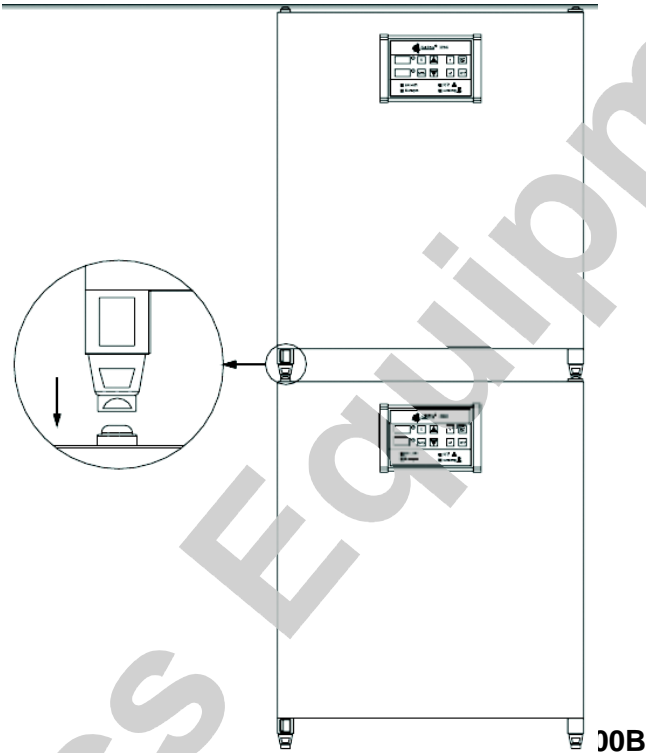

1 Stacking of Incubators (refer to Figure 9):-

- Additional aeration is needed if there are several equipments in one room or if the equipment is installed at the ground floor of the lab.
- The two equipments can stack together by the piling feet, which are riveted on the top of the equipment.

2 Capacity of Gas Under Normal and Abnormal Conditions:-

- **Gas required:** The necessary gas quantity for SET point.
- **Gas cost:** The gas quantity at max SET point.
- **Malfunction:** Gas output at the max SET point and in case of sound and light alarm (2h when malfunction).
- **Runoff the gas:** The max gas input through the capillary per hour when the valve is open.

Type of Gas	Pressure of Entrance	Capillary	Excretion of Gas (4)	Requirement of Gas (1)
CO ₂	1 Bar	0.65mm	222L/h	-50L

Type of Gas	Cost of Gas (2)	Excretion of Gas when Malfunction (3)	High-point
CO ₂	-0.52L/h	444L	5L/m3

3. Consumption of CO₂ (door closed):-

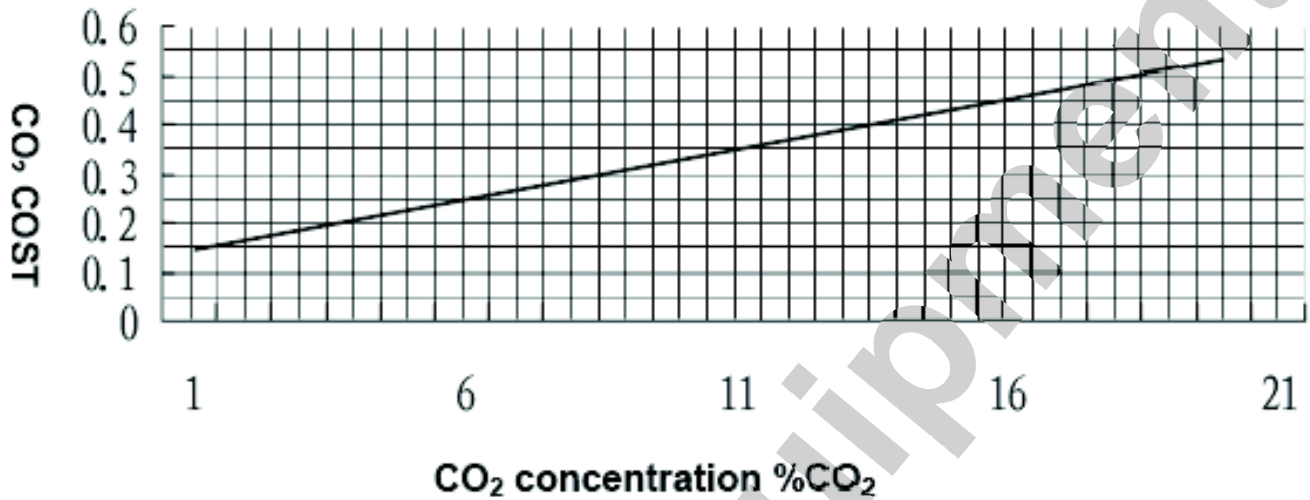

Fig. 10: Consumption of CO₂ (Door Closed)

4. pH value of incubation liquid:-

The pH value is affected by the concentration of CO₂ inside the incubator.

The following picture shows the relationship between pH value and Co₂ concentration.

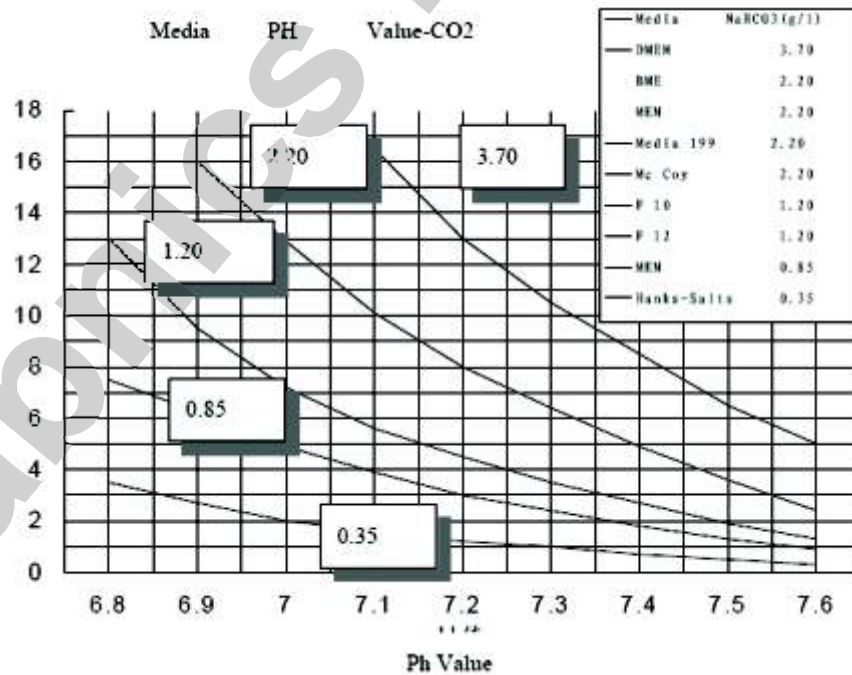

Fig. 11: pH value concentration of CO₂ inside the incubator

CHAPTER 14. SERVICE REPORT:-

Customer's Address : _____ _____	Tel.No.: _____ Fax No.: _____ Weekly Off.: _____
Contact Person / Designation : _____	Dept.: _____

Date	Time		System Configuration	Model	Serial No.	Date :	SR. No.
	From	To				Status : OK <input type="checkbox"/>	Not OK <input type="checkbox"/>
						Installation <input type="checkbox"/>	Warranty <input type="checkbox"/>
						Demonstration <input type="checkbox"/>	
						Maintenance <input type="checkbox"/>	Contract <input type="checkbox"/>
						Repairs <input type="checkbox"/>	
						Application <input type="checkbox"/>	Billable <input type="checkbox"/>
						Calibration <input type="checkbox"/>	
						Validation <input type="checkbox"/>	Courtesy <input type="checkbox"/>

Nature of Problem : _____

Observation & Action Taken : _____

Customer's Remarks : _____

Parts Replaced : _____

Parts Recommended / Action Required : Yes <input type="checkbox"/> No <input type="checkbox"/>		Requisition Number :
Service Engineer's Name & Signature	Customer's Name, Signature, Date & Stamp	